

Operating Instruction for AC/DC TRMS CLAMP METER with Datalogger & Mobile APP



Please read this manual before switching the unit on.
Important safety information inside.



Content	Page
1.Introduction.....	4
2.Safety.....	5
3.Description.....	6
3-1.Meter Description.....	6
3-2.Symbols Used on LCD Display.....	7
3-3.Key Description.....	7
4.Operation.....	8
4-1.AC/DC Current Measurements	8
4-2.Inrush Current Measurements.....	9
4-3.AC/DC Voltage Measurements.....	9
4-4.AC+DC Voltage Measurements.....	10
4-5.Frequency Measurements.....	10
4-6.VFD Mode.....	10
4-7.LoZ AC Voltage Measurements.....	11
4-8.Resistance Measurements.....	11
4-9.Continuity Check.....	12
4-10.Diode Test.....	12
4-11.Capacitance Measurements.....	13
4-12.Temperature Measurements.....	13
4-13.Flexible Coil Current Measurements.....	14
4-14.Using RANGE.....	14
4-15.Hold Mode.....	15
4-16.Capturing Minimum and Maximum Values.....	15
4-17.Relative Values.....	15
4-18.Capturing Peak Values.....	15
4-19.Non-Contact AC Voltage Measurement.....	16
5.Menu Operation.....	17
5-1.Settings Details.....	17
5-2.Data/Time Details.....	17
5-3.Measurement Details.....	17
5-4.Recording Details.....	18
5-5.Meter Info Details.....	19
5-6.Factory Set Details.....	20
6.Maintenance.....	20
6-1.Cleaning and Storage.....	20
6-2.Battery Replacement.....	20
6-3.Temperature Probe Replacement.....	20
7.Specifications.....	21
7-1.Specifications.....	21
7-2.General Specifications.....	23

1. Introduction

- Professional True RMS Industrial Digital Clamp meter and TFT color LCD display, providing fast A/D converting sampling time, high accuracy.
- It is easy to find and solve the problems of the production equipments, providing Bluetooth technology.
- It is much more safe measurements with double molded plastic housing design.

The Clamp Meter Measures or Tests:

- AC TRMS Current
- DC Current
- AC, AC+DC TRMS Voltage
- DC Voltage
- Resistance and Continuity Test
- Diode Test
- Capacity
- Frequency
- Duty Cycle
- Temperature with K-Type Probe
- Flexible Coils Current

The True RMS AC/DC Current Clamp Meter Features:

- Memory Function
- Menu Function
- Data Hold
- Peak Mode Measures
- Max/Min Mode Measures
- Relative Mode Measures
- VFD AC Voltage Measures
- INRUSH Current Measures

2.Safety

International Safety Symbols

 This symbol, adjacent to another symbol or terminal, indicates the user must refer to the manual for further information.

 This symbol, adjacent to a terminal, indicates that, under normal use, hazardous voltages may be present.

 Double insulation.

SAFETY NOTES

- Do not exceed the maximum allowable input range of any function.
- Do not apply voltage to meter when resistance function is selected.
- Set the function switch OFF when the meter is not in use.
- Remove the battery if meter is to be stored for longer than 60 days.

WARNINGS

- Set function switch to the appropriate position before measuring.
- When measuring volts do not switch to current/resistance modes.
- Do not measure current on a circuit whose voltage exceeds 600V.
- When changing ranges always disconnect the test leads from the circuit under test.

CAUTIONS

- Improper use of this meter can cause damage, shock, injury or death. Read and understand this user manual before operating the meter.
- Always remove the test leads before replacing the battery or fuses.
- Inspect the condition of the test leads and the meter itself for any damage before operating the meter. Repair or replace any damage before use.
- Use great care when making measurements if the voltages are greater than 25VAC rms or 35VDC. These voltages are considered a shock hazard.
- Always discharge capacitors and remove power from the device under test before performing Diode, Resistance or Continuity tests.
- Voltage checks on electrical outlets can be difficult and misleading because of the uncertainty of connection to the recessed electrical contacts. Other means should be used to ensure that the terminals are not "live".
- If the equipment is used in a manner not specified by the manufacturer, the protection provided by the equipment may be impaired.

3. Description

3-1. Meter Description

- 1-Current Clamp
- 2-Non-Contact AC Voltage Indicator Light
- 3-Clamp Trigger
- 4-Relative/INRUSH/ESC Button
- 5-LCD Display
- 6-MODE/VFD Button
- 7-RANGE Button
- 8-MENU Button
- 9-Rotary Function Switch
- 10-Data Hold/Flashlight Button
- 11-Battery Cover
- 12-COM Input Jack
- 13-V Ω Hz% CAP TEMP Jack
- 14-Flashlight

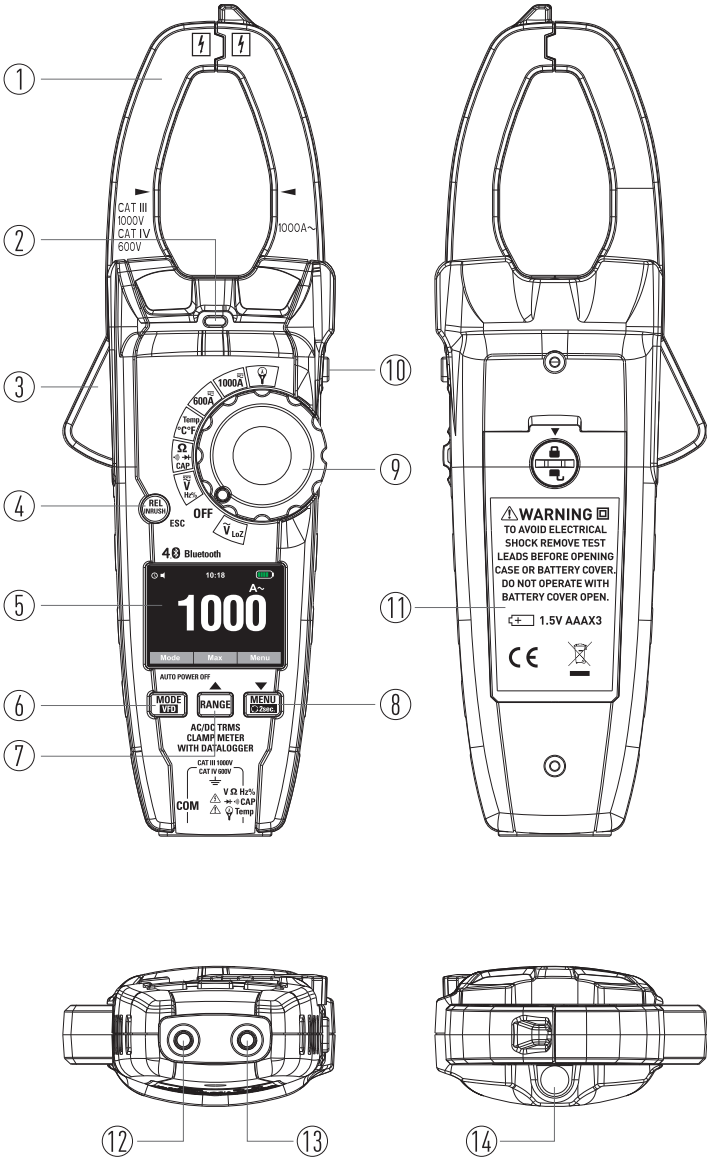

3-2. Symbols Used on LCD Display

- 1-Indication of Auto Power Off Function
- 2-Indication Key Beeper Function
- 3-Indication Bluetooth Function
- 4-Indication of Automatic/Manual Mode
- 5-Indication of the System's Time
- 6-Indication Battery Capacity
- 7-Indication of Measuring Unit
- 8-Indication of Measuring Result
- 9-Analogue Bar Graph
- 10-Indications Associated with Function Keys

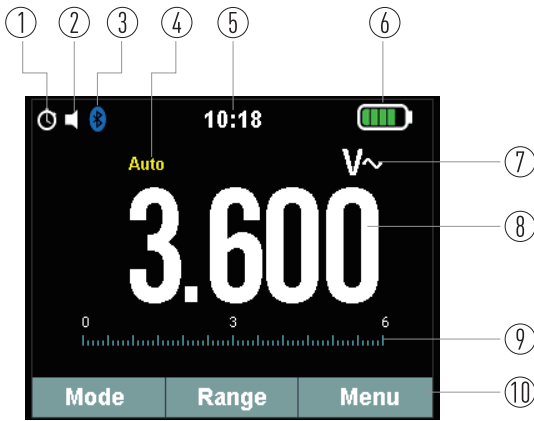

3-3. Key Description

- 1.MODE: Press the Mode key to switch the functions. And press 2 second switch VFD AC Voltage when AC Voltage measurement.
- 2.RANGE: Press the Range key to manage range. And press 2 second release when manual range measurement.
- 3.MENU: Press the menu key to open the menu functions. And press 2 second refer soft key function when measurement function is more.
- 4.REL: Press the Rel key to switch Relative measurement. And press 2 second switch to inrush function when 600A or 1000A AC current measurement.
- 5.HOLD: Freezes the present reading in the display and allows the display to be saved. And press 2 second turn on or off Flash Led.

4.Operation

NOTES: Read and understand all Warning and Caution statements in this operation manual prior to using this meter.

NOTES: Set the function select switch to the OFF position when the meter is not in use.

4-1.AC/DC Current Measurements

WARNING: Ensure that the test leads are disconnected from the meter before making current clamp measurements.

- 1.Set the Function switch to the **1000A**, **600A** range, If the approx. range of the measurement is not known, select the highest range then move to the lower ranges if necessary.
- 2.Use the **MODE** button to select AC or DC.
- 3.Press the **REL** button to zero the meter display.
- 4.Press the trigger to open jaw. Fully enclose only one conductor. For optimum results, center the conductor in the jaw.
- 5.The clamp meter LCD will display the reading.

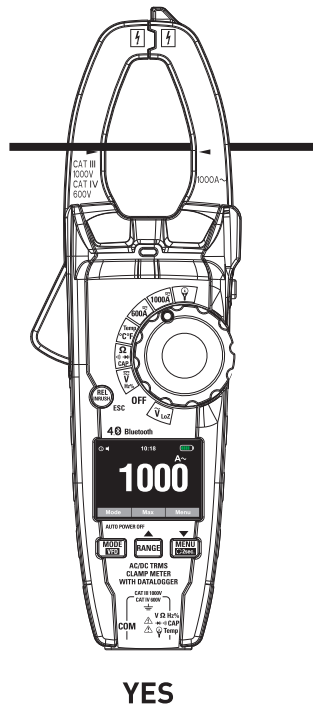
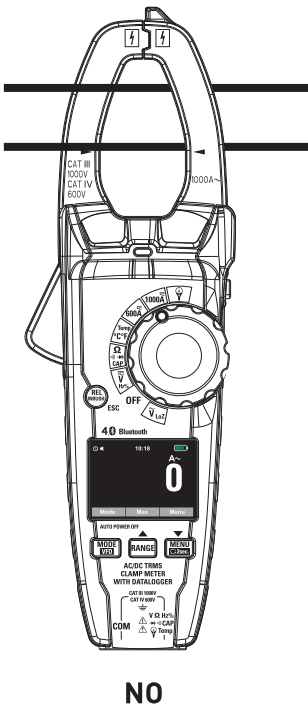

4-2. Inrush Current Measurements

1. Set the function switch to the **600A** or **1000A** position.
2. Press the **INRUSH** button (Enter key 2 second) to indicate "Inrush" on the display. Then measurement display "----".
3. Clamp the cable to be motor.
4. The motor start.
5. Read the inrush current in the display.

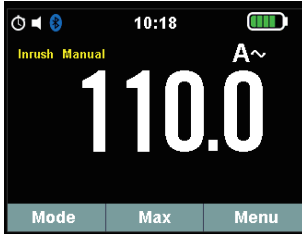

4-3. AC/DC Voltage Measurements

WARNING: Risk of Electrocutation. The probe tips may not be long enough to contact the live parts inside some 240V outlets for appliances because the contacts are recessed deep in the outlets. As a result, the reading may show 0 volts when the outlet actually has voltage on it. Make sure the probe tips are touching the metal contacts inside the outlet before assuming that no voltage is present.

CAUTION: Do not measure AC/DC voltages if a motor on the circuit is being switched ON or OFF. Large voltage surges may occur that can damage the meter.

1. Set the function switch to the **V AC/DC** position.
2. Insert the black test lead banana plug into the negative **COM** jack. Insert the red test lead banana plug into the positive **V** jack.
3. Press the **MODE** key to switch AC or DC Voltage functions.
4. Read the voltage in the display.

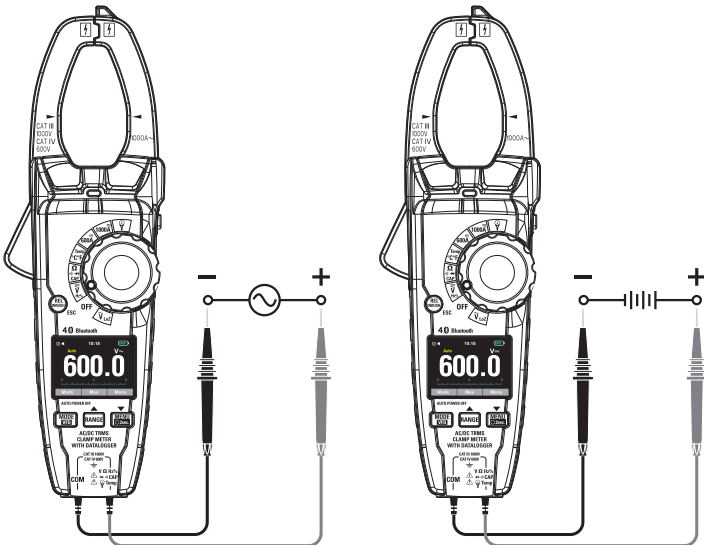

4-4.AC+DC Voltage Measurements

CAUTION: Do not measure DC voltages if a motor on the circuit is being switched ON or OFF. Large voltage surges may occur that can damage the meter.

- 1.Set the function switch to the **V AC/DC** position.
- 2.Insert the black test lead banana plug into the negative **COM** jack. Insert the red test lead banana plug into the positive **V** jack.
- 3.Press the **MODE** key to switch the V AC+DC Voltage functions.
- 4.Read the AC+DC voltage in the display.

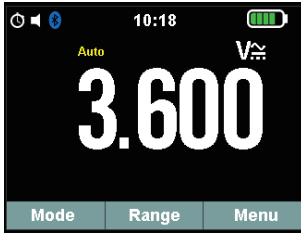

4-5.Frequency Measurements

- 1.Set the function switch to the **V AC/DC** position.
- 2.Insert the black test lead banana plug into the negative **COM** jack. Insert the red test lead banana plug into the positive **V** jack.
- 3.Press 2 second refer soft key function when measurement function is more.
- 4.Press the soft key Hz key to switch the Hz functions.
- 5.Read the Frequency in the display.
- 6.Press the soft key Hz to switch the Duty functions.
- 7.Read the Duty in the display.

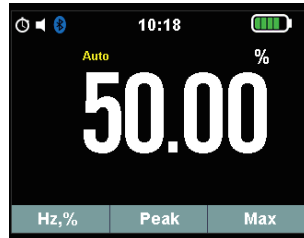
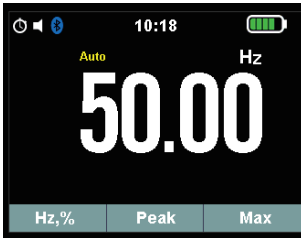

4-6.VFD Mode

- 1.Set the function switch to the **V AC/DC** to AC Voltage measurements.
- 2.Press the **VFD** button(MODE key 2 second) to indicate "VFD" on the display.
To variable frequency driver measurements.
- 3.Read Measurement in the display

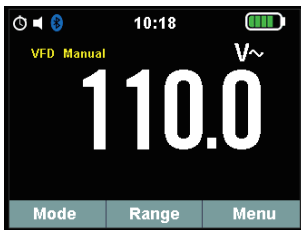

4-7. LoZ AC Voltage Measurements

WARNING: Risk of Electrocution. The probe tips may not be long enough to contact the live parts inside some 240V outlets for appliances because the contacts are recessed deep in the outlets. As a result, the reading may show 0 volts when the outlet actually has voltage on it. Make sure the probe tips are touching the metal contacts inside the outlet before assuming that no voltage is present.

CAUTION: Do not measure AC voltages if a motor on the circuit is being switched ON or OFF. Large voltage surges may occur that can damage the meter.

1. Set the function switch to the **VAC LoZ** position.
2. Insert the black test lead banana plug into the negative **COM** jack. Insert red test lead banana plug into the positive **V** jack.
3. Read the voltage in the main display.

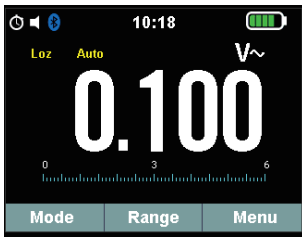

4-8. Resistance Measurements

To avoid electric shock, disconnect power to the unit under test and discharge all capacitors before taking any resistance measurements. Remove the batteries and unplug the line cords.

1. Set the function switch to the Ω \rightarrow CAP position.
2. Insert the black test lead banana plug into the negative **COM** jack. Insert the red test lead banana plug into the positive Ω Jack.
3. Read the resistance in the display. If the circuit is open, the display will indicate "OL".

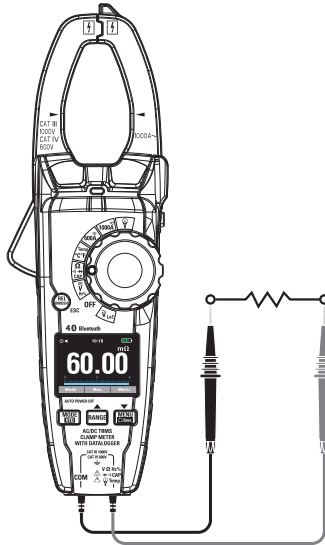

4-9. Continuity Check

WARNING: To avoid electric shock, disconnect power to the unit under test and discharge all capacitors before taking any resistance measurements. Remove the batteries and unplug the line cords.

1. Set the function switch to the Ω \rightarrow CAP position.
2. Insert the black test lead banana plug into the negative **COM** jack. Insert the red test lead banana plug into the positive jack.
3. Press the **MODE** key to switch the continuity functions.
4. If the resistance is less than approximately 50Ω , the audible signal will sound. If the circuit is open, the display will indicate "OL".

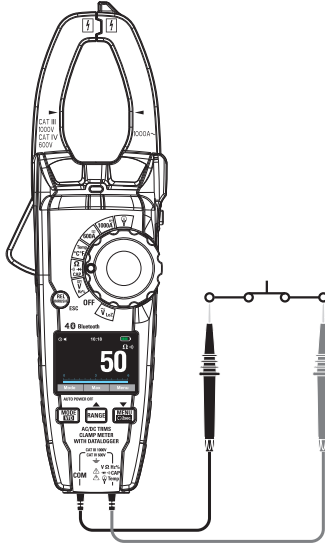

4-10. Diode Test

1. Set the function switch to the Ω \rightarrow CAP position.
2. Insert the black test lead banana plug into the negative **COM** jack and the red test lead banana plug into the positive **V** jack.
3. Press the **MODE** key to switch the Diode functions.
4. Forward voltage will typically indicate 0.400V to 3.000V. Reverse voltage will indicate "OL". Shorted devices will indicate near 0V and an open device will indicate "OL" in both polarities.

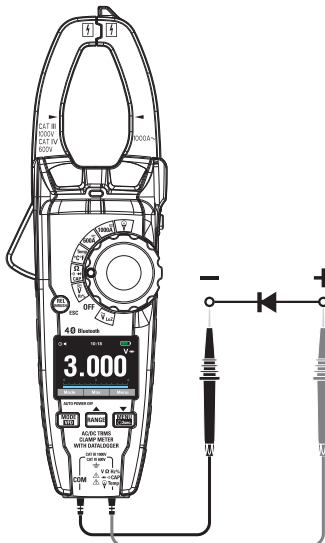

4-11. Capacitance Measurements

WARNING: To avoid electric shock, disconnect power to the unit under test and discharge all capacitors before taking any capacitance measurements. Remove the batteries and unplug the line cords.

1. Set the rotary function switch to the Ω \rightarrow CAP position.
2. Insert the black test lead banana plug into the negative **COM** jack. Insert the red test lead banana plug into the positive **V** jack.
3. Press the **MODE** key to switch the Capacitance functions.
4. Read the capacitance value in the Display.

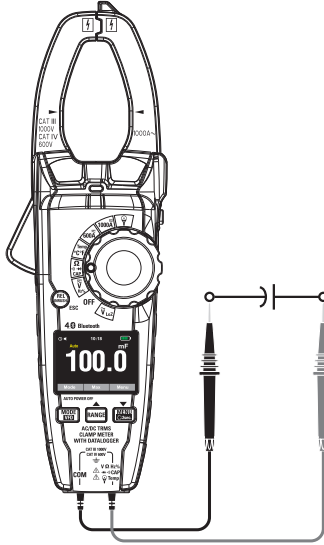

4-12. Temperature Measurements

1. Set the function switch to the **TEMP** position.
2. Insert the Temperature Probe into the input jacks, making sure to observe the correct polarity.
3. Read the temperature in the display
4. Press the **MODE** key to switch the Unit ($^{\circ}\text{C}$ or $^{\circ}\text{F}$).

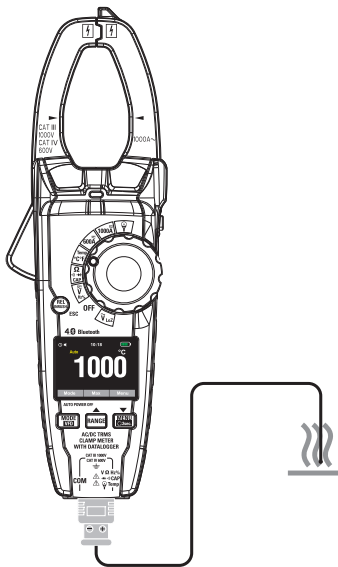

4-13. Flexible Coil Current Measurements

1. Set the function switch to the Flexible coil position.
2. Insert the black test lead banana plug into the negative **COM** jack. Insert the red test lead banana plug into the positive **V** jack.
3. Read the Current in the display.
4. Press the **RANGE** key to switch range. 30A, 300A, 3000A.

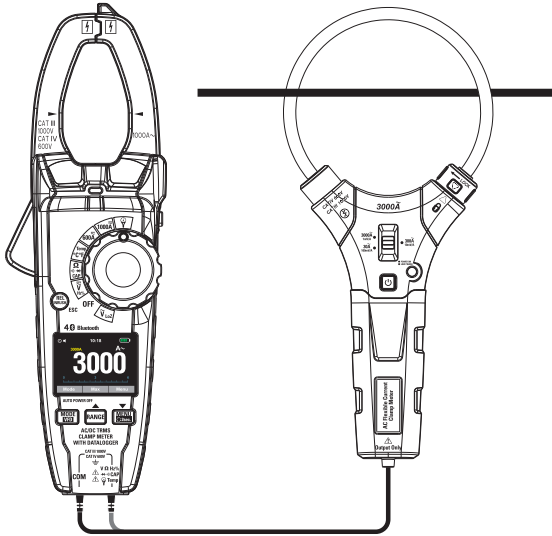

4-14. Using RANGE

- Press the **RANGE** key to activate the manual mode and to disable the Auto range function.
- The message "Manual" appears on the upper left part of the display instead of "Auto".
- In manual mode, press the **RANGE** key to change measuring range: the relevant decimal point will change its position.
- The **RANGE** key is not active in positions \rightarrow , \rightarrow , %, Temp °C/F, 600A ACDC, 1000A ACDC.
- In Auto range mode, the instrument selects the most appropriate ratio for carrying out measurement.
- If a reading is higher than the maximum measurable value, the indication "O.L." appears on the display.
- Press and hold the **RANGE** key for more than 1 second to exit the manual mode and restore the Auto range mode.

Auto (or manual) mode fig below:

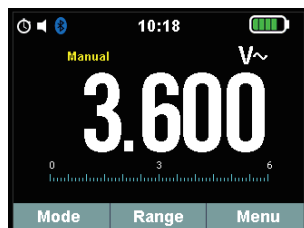
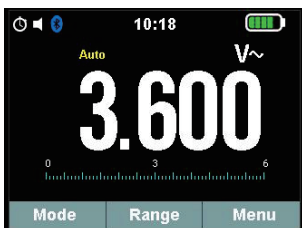

4-15. Hold Mode

- To freeze the display for any function, press key **HOLD**. And again press key **HOLD** to release freeze.
- Press soft key save will store the measurement to memory.

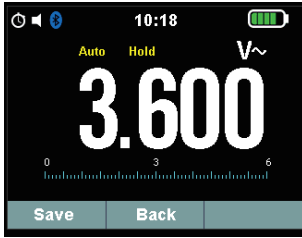

4-16. Capturing Minimum and Maximum Values

- The MAX MIN Record mode captures minimum, and maximum input values.
- When the input goes below the recorded minimum value or above the recorded maximum value, the Meter beeps and records the new value.
- This mode is for capturing intermittent readings, recording minimum and maximum readings unattended, or recording readings while equipment operation precludes watching the Meter.
- To activate the MAX MIN mode, press softkey key max.
- If the Meter is already in MAX MIN function, press max causes the Meter to turn off MAX MIN function.

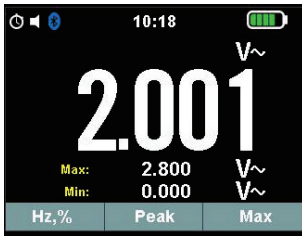

4-17. Relative Values

- To activate the relative mode, press the **REL** key.
- If the Meter is already in the relative function, press **REL** key causes the Meter to turn off relative.



4-18. Capturing Peak Values

- In VAC measures, To activate the peak mode, press the soft key peak.
- If the Meter is already in the peak function, press peak causes the Meter to turn off peak function.

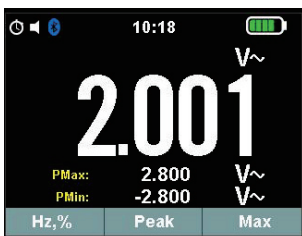

4-19. Non-Contact AC Voltage Measurement

WARNING: Risk of Electrocutation. Before use, always test the voltage detector on a known live circuit to verify proper operation.

1. Touch the probe tip to the hot conductor or insert into the hot side of the electrical outlet.
2. If AC voltage is present, the detector light will illuminate.

Note: The conductors in electrical cord sets are often twisted. For best results, rub the probe tip along a length of the cord to assure placing the tip in close proximity to the live conductor.

Note: The detector is designed with high sensitivity. Static electricity or other sources of energy may randomly trip the sensor. This is normal operation.

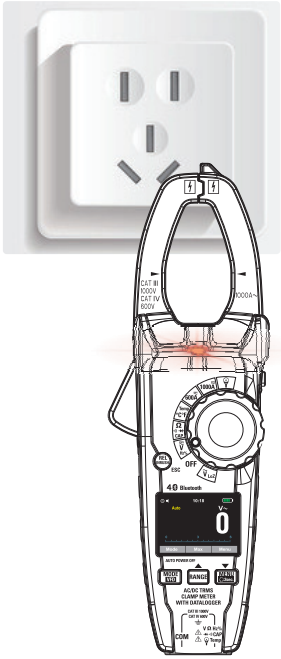

5.Menu Operation

- Press Menu button to open the Menus, As show below
- Press soft key Up / Down to select menu item or change the value of current focus item.
- Press soft key Enter to enter the submenu or set focus on the current selected item.
- Press ESC button to return to the previous menu.

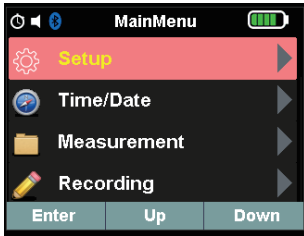

5-1.Settings Details

- Press soft key **Up/Down** to select setup item at main menu, And Press soft key **Enter** to enter.
- Four options are available: Key Sound, Bluetooth, 12 Hour and APO Time.
 - 1.Key Sound: Use Up/Down button to set beep on or off.
 - 2.Bluetooth: Use Up/Down button to turn Bluetooth on or off.
 - 3.12 Hour: Use Up/Down button to set Time 12 Hour on or 24 Hour.
 - 4.APO Time: Use Up/Down button to set Auto Power Off Time 15,30,45,60,and off.

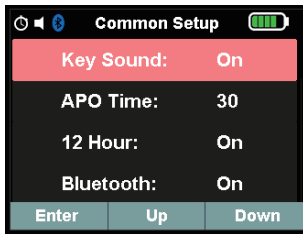

5-2.Data/Time Details

- Press soft key **Up/Down** to select Data/Time item at main menu, and Press soft key **Enter** to enter.
- In this menu, year, month, day, hour, minute can be set.

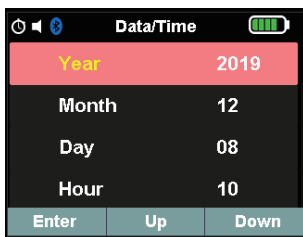

5-3.Measurement Details

- Press soft key **Up/Down** to select Measurement item at Measurement menu, and Press soft key **Enter** to enter the menu.

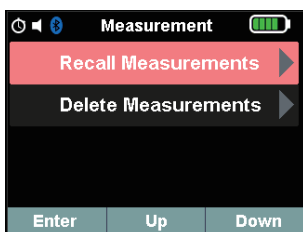

- Recall Measurement Item can Recall store measurement in Memory.
- Delete Measurements item will Delete all data in Memory.
- Recall measurement fig is below:



5-4. Recording Details

1. Press soft key **Up/Down** to select Recording item at main menu, and press soft key **Enter** to enter Recording Function. Recording Menu is below:



2. In Recording Menu. Press soft key **Up/Down** to select Setup New Recording Item, and press soft key **Enter** to enter set Duration and sample time. fig is below:

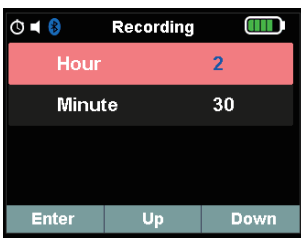
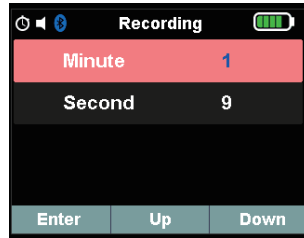
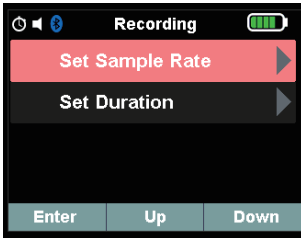

3. In Record Menu. Press soft key **Up/Down** to select Start recording Item, and press soft key **Enter** to start one new recording.

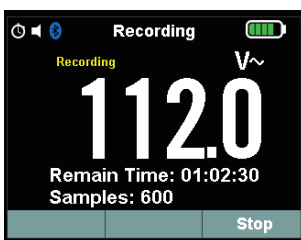

4. In Record Menu. Press soft key **Up/Down** to select Recall recordings Item, and press soft key Enter to enter recording in memory. Then Press soft key **Prev/Next** view last or next recording. Fig is below:

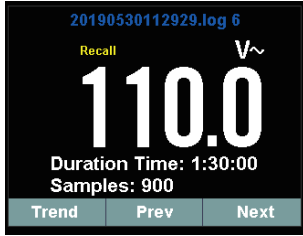

And Press soft key Trend to expansion graph. Fig is below:

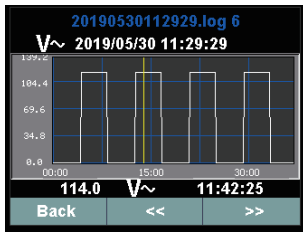

5. In Record Menu. Press soft key **Up/Down** to select Delete recordings Item, and press soft key Enter to enter delete all recording function.

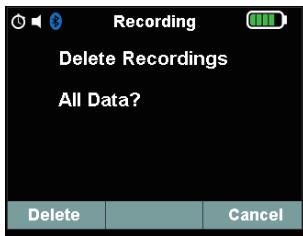

5-5. Meter Info Details

- Press soft key **Up/Down** to select Meter Info item at main menu, and Press soft key **Enter** to enter Meter info interface.
- This menu contains software's version, hardware's version and Free Memory.

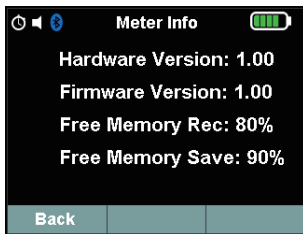

5-6.Factory Set Details

- Press soft key **Up/Down** to select Factory set item at main menu, And Press soft key **Enter** to enter Factory set interface.
- Select **"YES"** button, System setting will be reset. Fig is below:

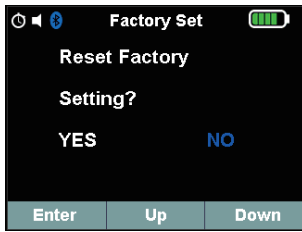

6.Maintenance

WARNING: To avoid electrical shock, disconnect the meter from any circuit, remove the test leads from the input terminals, and turn OFF the meter before opening the case. Do not operate the meter with an open case.

6-1.Cleaning and Storage

- Periodically wipe the case with a damp cloth and mild detergent; do not use abrasives or solvents.
- If the meter is not to be used for 60 days or more, remove the battery and store it separately.

6-2.Battery Replacement

- 1.Remove the Phillips head screw that secures the rear battery door.
- 2.Open the battery compartment.
- 3.Replace the AAA battery.
- 4.Secure the battery compartment.

6-3.Temperature Probe Replacement

Note: To use a Type K thermocouple probe that is terminated by a subminiature (flat blade) connector, a subminiature-to-banana plug adaptor is required.

7. Specifications

7-1. Specifications

Accuracy calculated as [%reading + (num. digits*resolution)] at 18 to 28°C;
<75%HR.

Function	Range	Resolution	Accuracy
DC Voltage	600.0mV	0.1mV	±(0.5% + 8 digits)
	6.000V	0.001V	±(1.5% + 5 digits)
	60.00V	0.01V	
	600.0V	0.1V	
	1000V	1V	

Input impedance>10MΩ; Protection against overcharge: 1000VDC/ACrms.

AC TRMS Voltage (50Hz-400Hz)	6.000V	0.001V	±(1.5% + 5 digits)
	60.00V	0.01V	
	600.0V	0.1V	
	1000V	1V	

Input impedance>9MΩ; Protection against overcharge: 1000VDC/ACrms.

Accuracy specified from 10% to 100% of the measuring range, sine wave.

Accuracy PEAK function: ±10%rdg, PEAK response time: 1ms.

VFD AC Voltage reading for reference only.

LowZ AC TRMS Voltage (50Hz-400Hz)	6.000V	0.001V	±(3.0% + 40 digits)
	60.00V	0.01V	
	300.0V	0.1V	

Input impedance<300kΩ; Protection against overcharge: 1000VDC/ACrms.

Accuracy specified from 10% to 100% of the measuring range, sine wave.

AC+DC TRMS Voltage (50Hz-400Hz)	6.000V	0.001V	±(2.5% + 20 digits)
	60.00V	0.01V	
	600.0V	0.1V	
	1000V	1V	

Input impedance>10MΩ; Protection against overcharge: 1000VDC/ACrms.

DC Current	600.0A	0.1A	±(2.5% + 5 digits)
	1000A	1A	±(2.8% + 5 digits)

Protection against overcharge: 1000ADC/ACrms.

AC TRMS Current (50Hz-60Hz)	600.0A	0.1A	±(2.5% + 5 digits)
	1000A	1A	±(2.8% + 5 digits)

Protection against overcharge: 1000ADC/ACrms.

Flexible Coil Current (50Hz-400Hz)	30.00A	0.01A	±(3.0% + 5 digits)
	300.0A	0.1A	
	3000A	1A	

Protection against overcharge: 3000ADC/ACrms.

Accuracy specified from 10% to 100% of the measuring range, sine wave.

Function	Range	Resolution	Accuracy
Resistance and Continuity Test	600.0 Ω	0.1 Ω	$\pm(1.0\% + 10 \text{ digits})$
	6.000k Ω	0.001k Ω	$\pm(1.5\% + 5 \text{ digits})$
	60.00k Ω	0.01k Ω	
	600.0k Ω	0.1k Ω	
	6.000M Ω	0.001M Ω	$\pm(2.5\% + 5 \text{ digits})$
	60.00M Ω	0.01M Ω	$\pm(3.5\% + 10 \text{ digits})$

Buzzer <50 Ω ; Protection against overcharge: 1000VDC/ACrms.

Diode Test	Test Current<1.5mA Max voltage with open circuit: 3.3VDC
------------	---

Frequency (Electronic circuits)	9.999Hz-99.99 kHz	0.01-10Hz	$\pm(1.2\% + 5 \text{ digits})$
------------------------------------	----------------------	-----------	---------------------------------

Protection against overcharge: 1000VDC/ACrms.

Sensitivity: >5Vrms (at 20% - 80% duty cycle).

Duty Cycle	10.0% - 90.0%	0.1%	$\pm(1.2\% + 8 \text{ digits})$
------------	---------------	------	---------------------------------

Pulse frequency range: 40Hz - 10kHz, Pulse amplitude: $\pm 5V$ (0.1ms - 100ms).

Capacity	60.00nF	0.01nF	$\pm(4.0\% + 20 \text{ digits})$
	600.0nF	0.1nF	$\pm(3.0\% + 8 \text{ digits})$
	6.000 μ F	0.001 μ F	
	60.00 μ F	0.01 μ F	
	600.0 μ F	0.1 μ F	
	6000 μ F	1 μ F	$\pm(5.0\% + 8 \text{ digits})$
	60.00mF	0.01mF	$\pm(5.0\% + 20 \text{ digits})$
	100.0mF	0.1mF	

Protection against overcharge: 1000VDC/ACrms.

Temperature with K-Type Probe	-40.0 to 600.0 $^{\circ}$ C	0.1 $^{\circ}$ C	$\pm(1.5\% + 5^{\circ}$ C)
	600 to 1000 $^{\circ}$ C	1 $^{\circ}$ C	
	-40.0 to 600.0 $^{\circ}$ F	0.1 $^{\circ}$ F	$\pm(1.5\% + 9^{\circ}$ F)
	600 to 1800 $^{\circ}$ F	1 $^{\circ}$ F	

Protection against overcharge: 1000VDC/ACrms.

Instrument accuracy without probe; Specified accuracy with stable environmental temperature at $\pm 1^{\circ}$ C.

For long-lasting measurements, reading increases by 2° C.

7-2. General Specifications

Clamp Jaw Opening	1.3" (34mm) approx.
Display	3-5/6 digits (6000 counts) TFT Color LCD
Continuity Check	Threshold 50 Ω ; Test current < 0.5mA.
Diode Test	Test current of 0.3mA typical; Open circuit voltage < 3.3VDC typical.
Over-Range Indication	"OL" display
Measurement Rate	3 readings per second, nominal
Peak	Captures peaks >1ms
Temperature Sensor	Type K thermocouple
Input Impedance	10M VDC and 9MVAC
AC Response	True rms (AAC and VAC)
Operating Temperature	5 to 40°C (41 to 104°F)
Storage Temperature	-20 to 60°C (-4 to 140°F)
Operating Humidity	Max 80% up to 31°C (87°F) decreasing linearly to 50% at 40°C (104°F)
Storage Humidity	<80%
Operating Altitude	7000ft. (2000meters) maximum.
Battery	Three (3) AAA battery
Auto Power Off	After approx. 15-60 minutes.
Safety	For indoor use and in accordance with the requirements for double insulation to IEC1010-1 (2001): EN61010-1 (2001) Overvoltage Category III 1000V and Category IV 600V, Pollution Degree 2.

AC/DC TRMS CLAMP METER

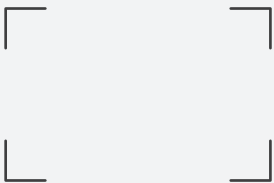

Rev.191031